

MRT PRIVILEGE+

2150 2540

TECHNICAL DATA SHEET



MRT PRIVILEGE +

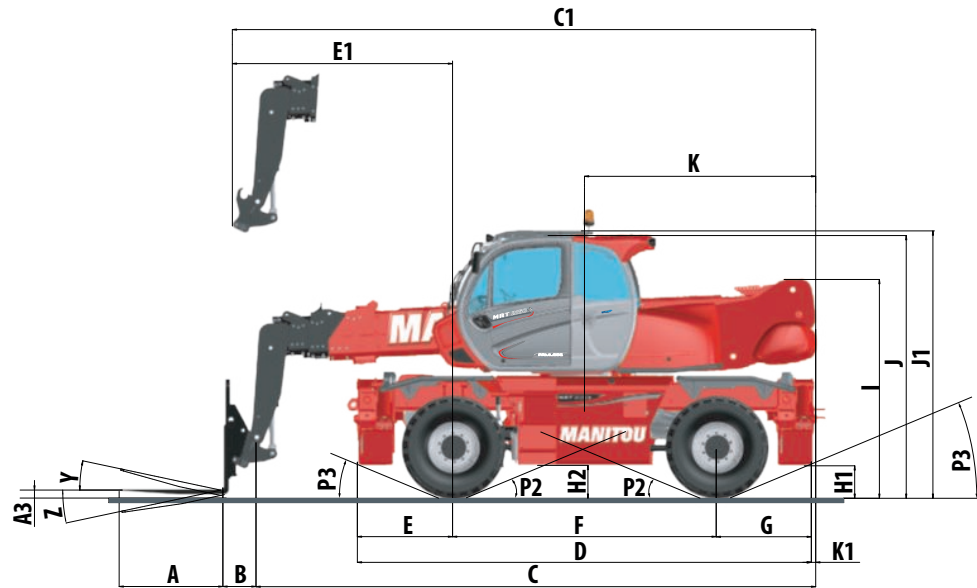

mm	MRT 2150/2540	
A	1200	
A1	150	
B	385	
C	6475	7445
C1	6825	7730
D	5350	
E	1150	
E1	2575	3045
F	3050	
G	1150	
H1	350	
H2	350	
I	2500	2520
J	3070	
J1	3130	
K	2675	3175

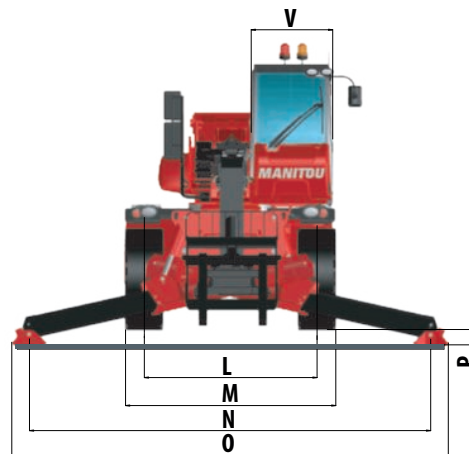

mm	MRT 2150 /2540	
K1	50	500
L	2010	
M	2465	
N	4700	
O	5115	
P	175	
P2	15°	
P3	22°	
Q	5235	
R	4650	
S	5190	
S1	4500	
T	4880	
U	6550	6915
V	950	
Y	12°	
Z	105°	

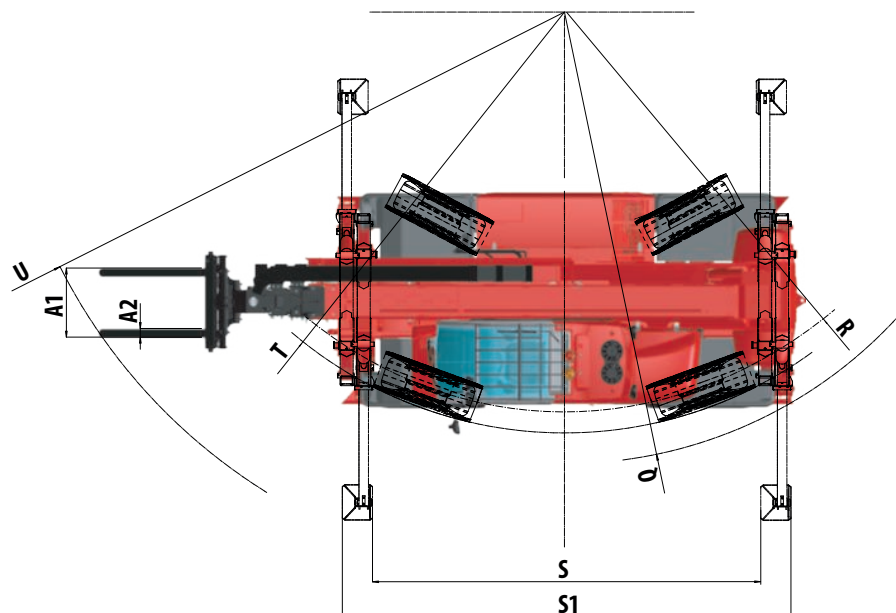

	MRT 2150 Privilege +	MRT 2540 Privilege +
Lifting		
Max. capacity with forks at 600 mm LC (on stabilizers)	4 999 kg	4 000 kg
Max. lifting height	20.67 m	24.60 m
Max. outreach.	18.10 m	18.50 m
Tyres	18 -22.5	
Frame levelling	on front axle +/- 8° oscillating rear axle with automatic hydraulic lock-out on rotation (> +/- 7.5°)	
Stabilizers	duplex telescopic simultaneously or individually controlled	
Full, continuous rotation	Turret mounted on a double slew ring with internal gearing / slewing system with negative brake	
Braking		
Service brake	oil-bath multiple-disc brakes hydraulically assisted on both axles	
Parking brake	Automatic negative parking brake	
Engine		
	MERCEDES	
Type	OM 934 E4-5 (Stage IV / Final tier IV)	
Displacement	4 cylinders - 5.13 liters	
Power	156 HP / 115 kW	
Max. torque	675 Nm / from 1200-1600 rpm	
Batteries	24 V : 2 x 12 V - 120 Ah - 850 A	
Laden drawbar pull	8 200 daN	
Gradability	40%	
Transmission		
	hydrostatic with power regulation (variable-displacement pump and hydrostatic motor)	
Steering mode	4 Wheel steer - 3 Steering modes 	
Max. travel speed (may vary according to applicable regulations)	36 km/h	
Controls	2 Joysticks multi - fonctions	
Hydraulics		
Load sensing Pump	115 l/min - 275 bar	
Capacities		
Hydraulic oil	297 l	
Fuel	361 l	
Urea (AdBlue® type)	54 l	
Unladen weight (with forks)	17 620 kg	18 600 kg
Dimensions		
Overall width	2.46 m	
Overall width (stabilizers extended)	5.11 m	
Overall height	3.05 m	
Overall length to carriage	6.86 m	7.83 m
Ground clearance	0.38 m	
Turning radius (over tyres)	4.88 m	
Standard forks (length x width x thickness)	1200 x 150 x 50 mm	
Safety		
	Load monitoring system - (crane norms) Attachment recognition system (E-Reco)	
Bruits et vibrations		
Noise at driving position (LpA)	79.7 dB	
Environmental noise (LwA)	104 dB	
Vibration to whole hand/arm	<2.5 m/s ²	

MRT 2150 + Privilege



Rotation on extended stabilizers
with **forks**

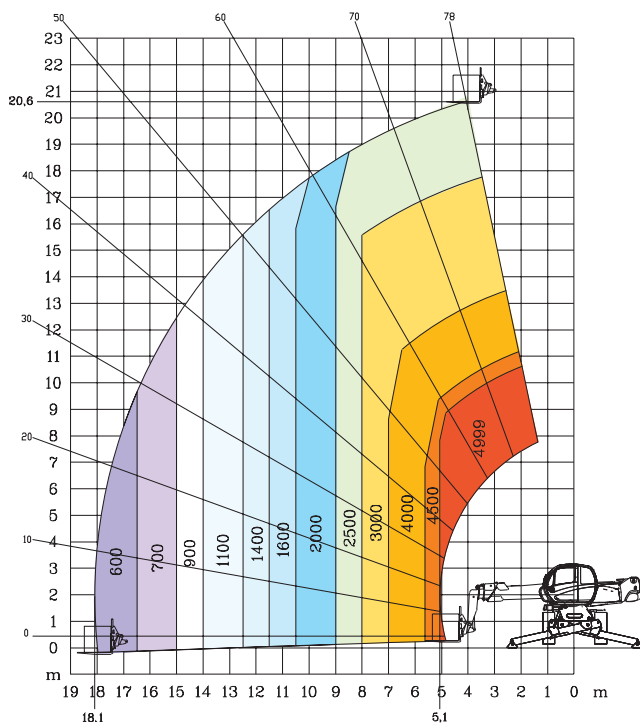

Frontal on wheels
with **forks**

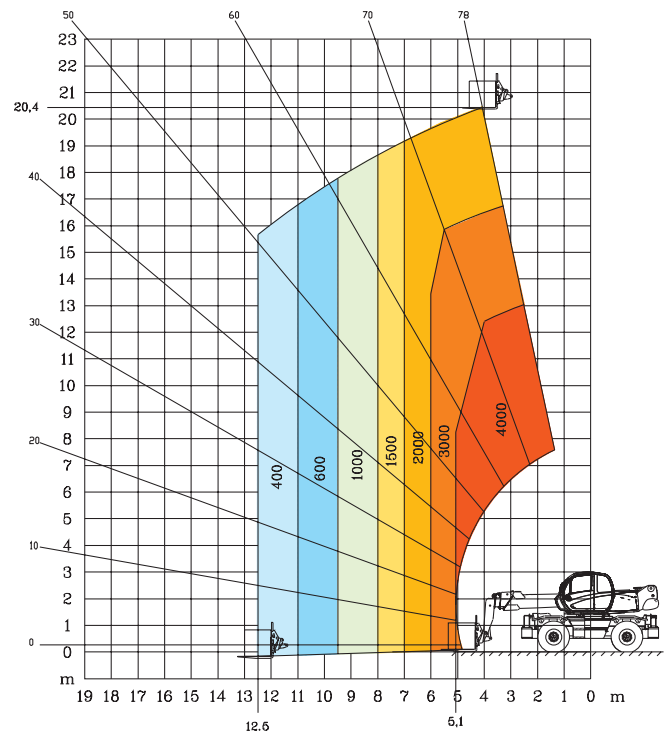

Rock-solid efficiency

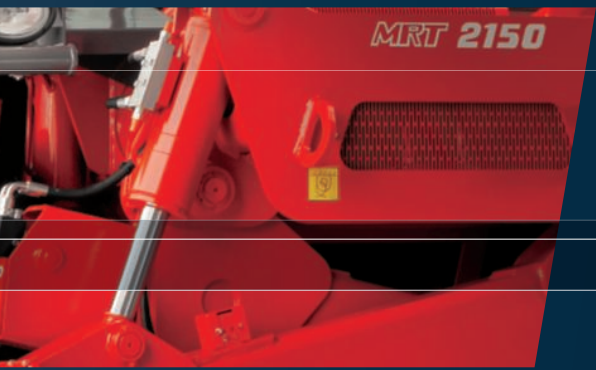

Rotation on extended stabilizers
with **5000 kg winch**

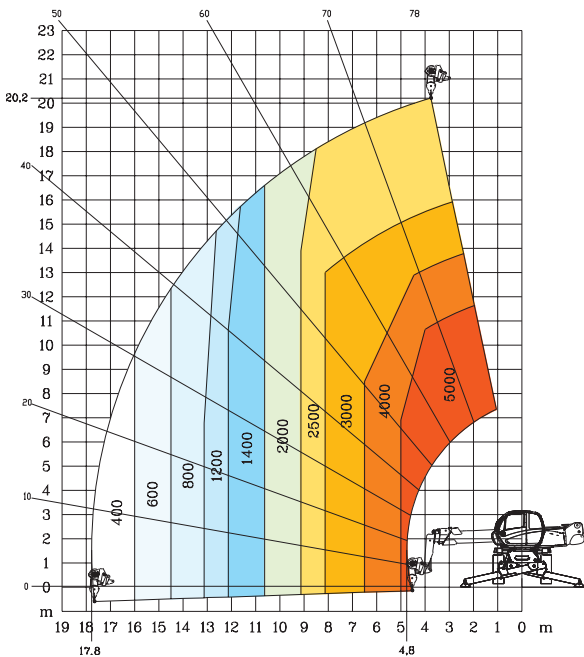

Rotation on extended stabilizers
with **1500 kg jib**



Rotation on extended stabilizers
with **365/1000 kg platform**

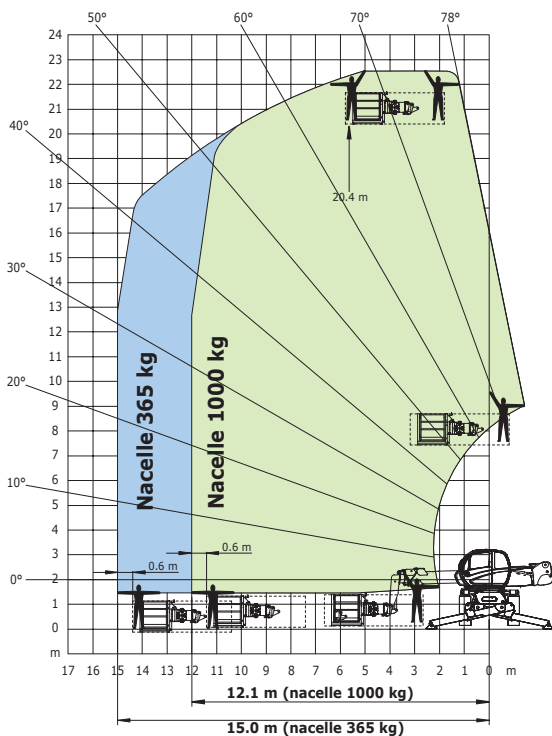

Rotation on extended stabilizers
3D positive / négative

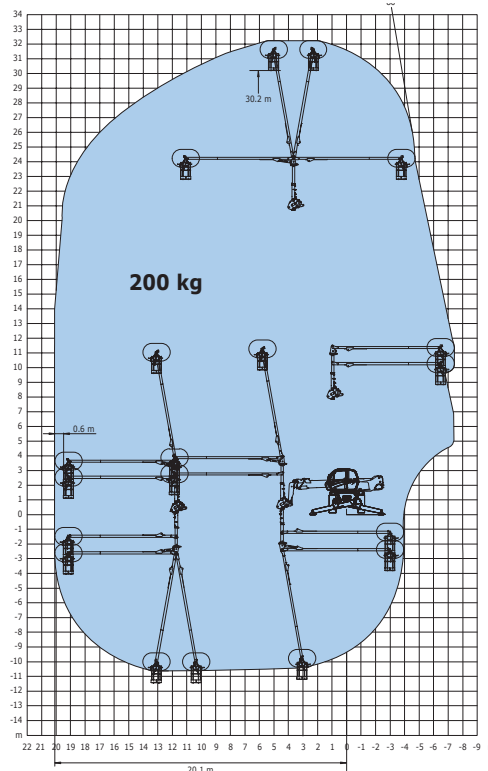

// MRT 2150 +

MRT 2540 + Privilege



**Rotation on extended stabilizers
with forks**

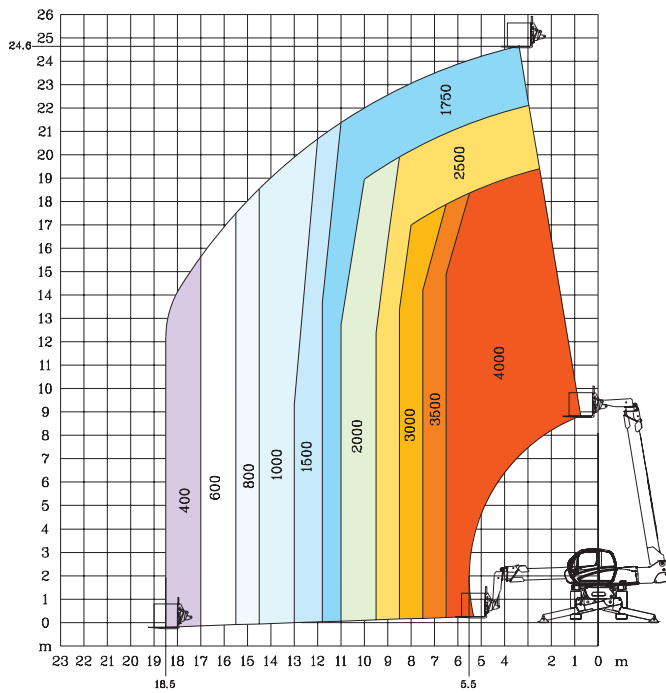

**Frontal on wheels
with forks**

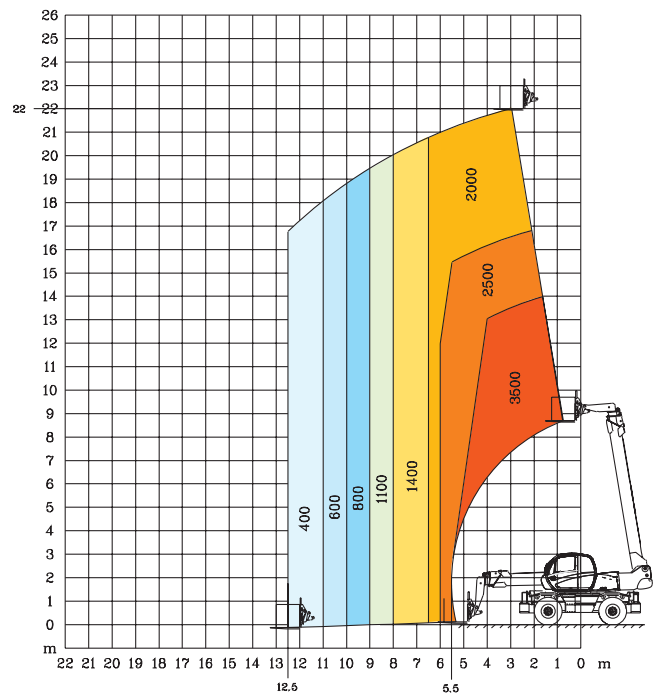

Rock-solid efficiency



Rotation on extended stabilizers with **5000 kg winch**

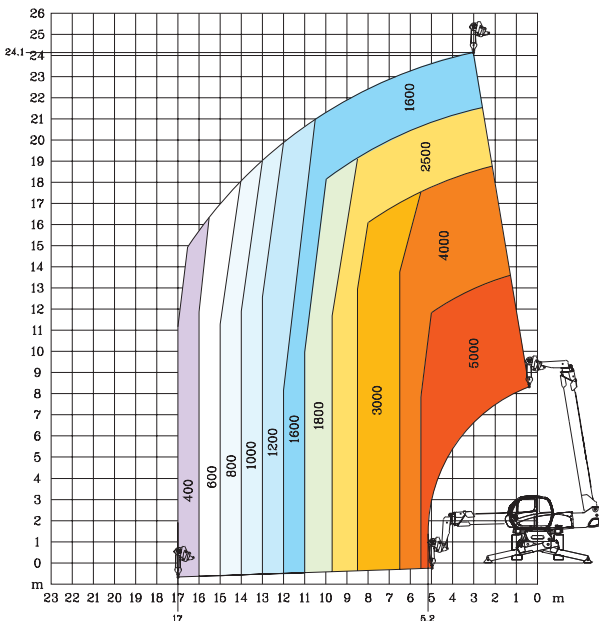

Rotation on extended stabilizers with **1500 kg jib**

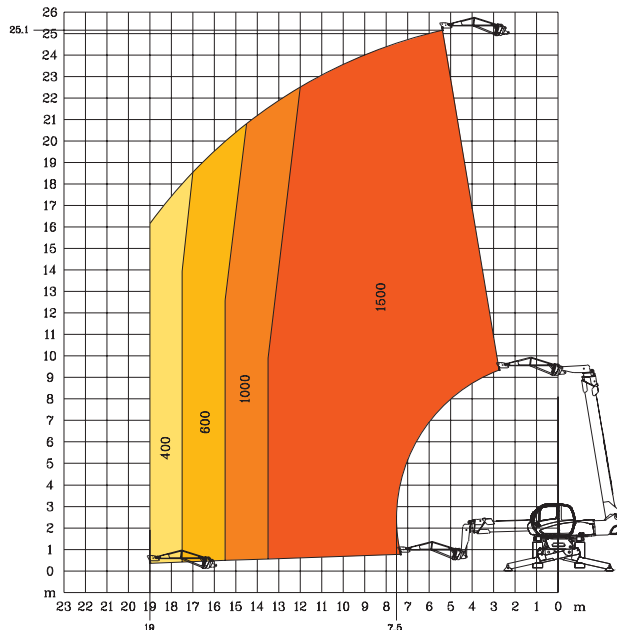

Rotation on extended stabilizers with **365/1000 kg platform**

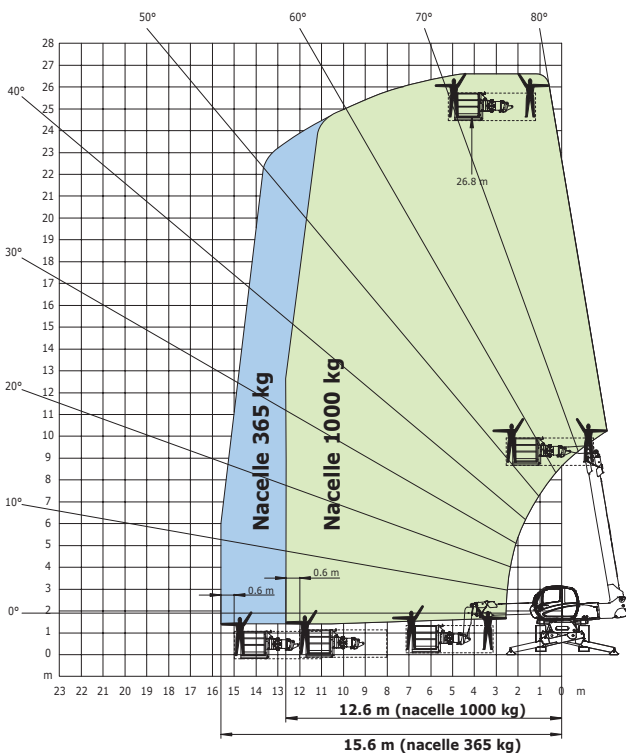

Rotation on extended stabilizers **3D positive / négative**

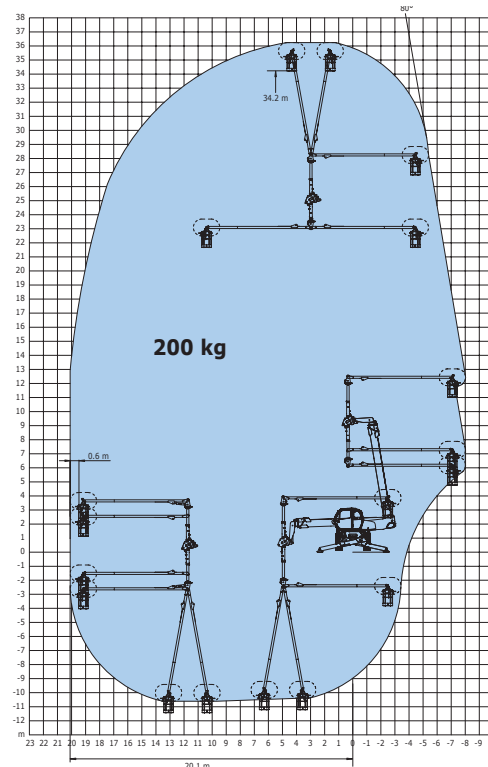

// MRT 2540 +

Your **MANITOU** dealers:



Head office:
B.P. 249 - 430 rue de l'Aubinière - 44158 Ancenis Cedex - France
Tel.: 00 33 (0)2 40 09 10 11 - Fax: 00 33 (0)2 40 83 36 88
www.manitou.com