

Snake 2413 plus

ON ISUZU M21 GROUND BLUE H



PM Oil&Steel SpA

IT - 41018 S. Cesario Sul Panaro MO
Via G. Verdi, 22
tel. +39 059 936811 • fax +39 059 936804
info@oilsteel.it • www.oilsteel.com

Oil&Steel is a brand of Manitex International

OIL & STEEL
AERIAL PLATFORMS

AERIAL PLATFORM STANDARD EQUIPMENT

- Power takeoff with electrical start-up and automatic release
- Power takeoff on with no handbrake warning siren
- Power takeoff hour counter fitted on the dashboard of the vehicle
- Warning lights on the hour counter inside the cabin showing PTO ON and outriggers outside the vehicle profile
- Start-up and shutdown of the main engine [and potential auxiliary engine] from the basket and from the column
- Engine emergency stop button from the basket and from the column
- Single-phase, 220 or 110 VAC power socket and differential overload switch fitted on the basket
- Truck cabin anti-collision system
- Moment detection and limiting system
- Geometric limiting system
- Hand pump for emergency descent
- Aerial part controls: electro-hydraulic
- Outrigger controls: hydraulic
- Manual extension of front crosspieces
- Possibility to work with front crosspieces both opened, both closed, one side opened, one side closed
- Hoses and cables inside the booms
- Two-person aluminium basket with dimensions 1400x700xh1100 mm [front entrance]
- Hydraulic rotation of the basket 90° right - 90° left with rotary actuator
- Protective casing for control box on the column and on the basket
- Thermal protection on the electrical system
- Lock valves on all cylinders
- Hydraulic circuit maximum pressure valves
- Anti-slip aluminium decking
- Standard painting white RAL 9016

TRUCK STANDARD FEATURES

ISUZU M2I GROUND BLUE H wheelbase 2760 mm 1900 cc engine - 123 HP EGR - DPD - LNT

- Adjustable steering wheel (tilt and height)
- Power windows
- Manual headlamp leveling system
- Reverse warning beeper
- Front and rear fog lamps
- Day-time running lights immobilizer
- Central Locking with remote control
- Sun visor (driver's seat)

OPTIONAL

- Boom and platform treated using corrosion-resistant paint, screws in stainless steel
- Water air-line supply to the basket
- Hydraulic extension of front crosspieces
- Electro-hydraulic extension of front crosspieces [it includes automatic stabilization from the basket + homing function aerial part]
- Homing function [automatic shut-down of the aerial part]
- Underride guards
- Underride guards with plastic toolbox [only if plastic toolbox is included as optional]
- Kit junction protection
- Oil tank protection cover
- Oil tank protection cover + additional flatbed on the left side
- Fiberglass basket 1400 x 700 x 1100 mm [instead of standard] non-insulated
- Fiberglass basket 1400 x 700 x 1100 mm + 1KV insulation [instead of standard]
- Step to access the rear right flatbed [instead of standard]
- Kit 4 nylon outrigger pads
- Working height limiting device
- Tilt sensor
- 12V DC socket
- 12V DC socket + Working light 60W on basket
- Kit 2 harnesses with rope
- Electrical pump 12V DC 1.6 kW for emergency descent
- Auxiliary single-phase 110VAC or 220VAC - 2.2 kW electrical pump [electrical control panel and battery charger powered by an external source]
- 12V revolving orange light for truck cabin
- 12V revolving blue light for truck cabin
- 12V revolving orange light for truck cabin + bar
- 12V revolving orange light for truck cabin + triflash bar
- Plastic toolbox with dimensions 480 x 400 x 400mm placed under the deck
- Red and white reflective decals on truck
- Fixed aluminium side panels 100mm / 150 mm / 200 mm height
- Drop-down panels on 1 side (right) with 100 mm / 150 mm / 200 mm height
- Drop-down panels on 2 sides with 100 mm / 150 mm / 200 mm height
- Extended warranty 2 years [+1 year in addition to standard warranty conditions]
- Extended warranty 3 years [+2 years in addition to standard warranty conditions]
- Air conditioning system
- Truck cabin painting different from standard [external part only] - std RAL colors
- Aerial part painting different from standard [std RAL colors]

CROSSBEAMS FULLY OPENED

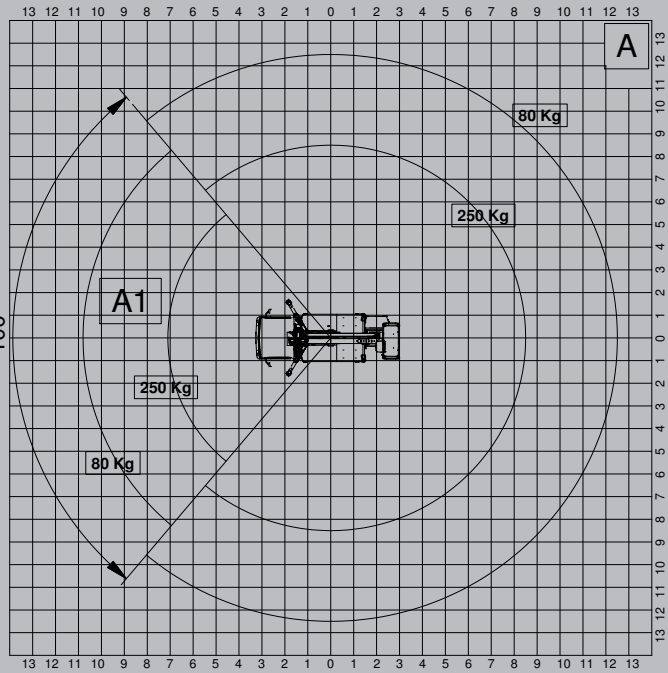
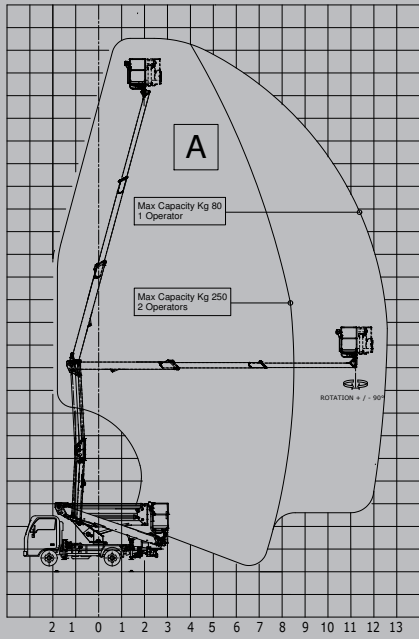

CROSSBEAMS CLOSED

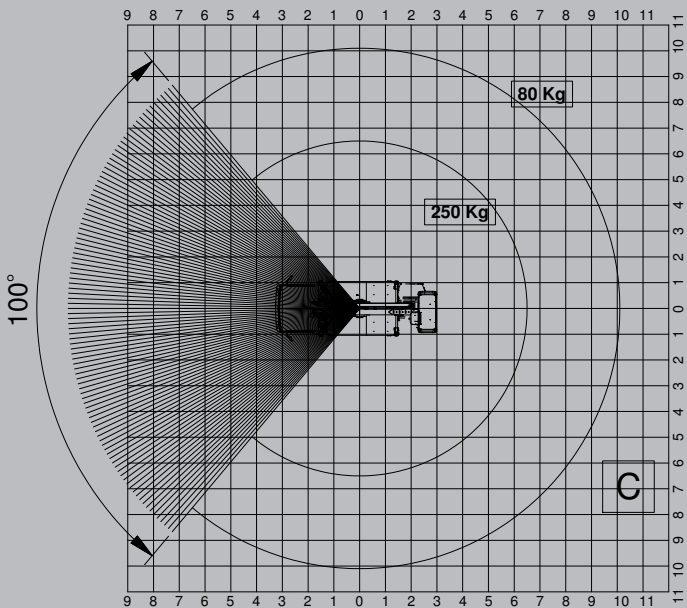
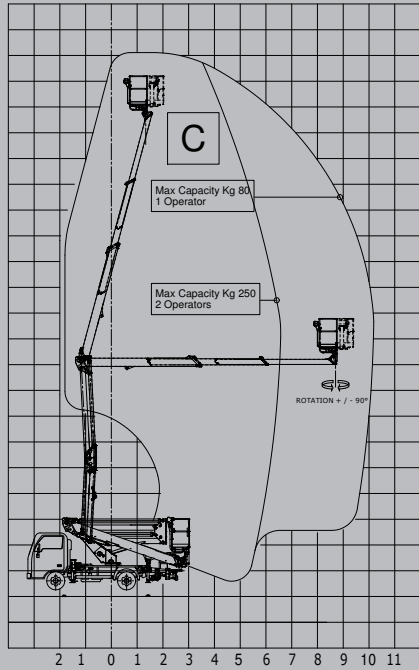

CROSSBEAMS ONE SIDE FULLY OPENED ONE SIDE CLOSED

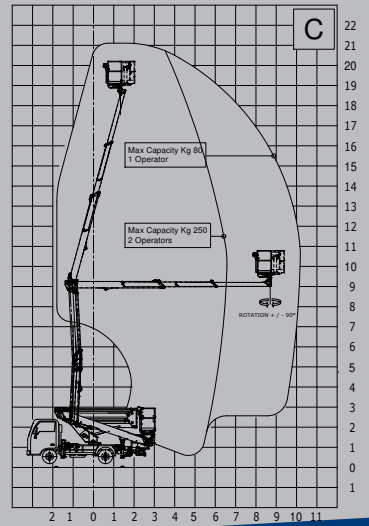
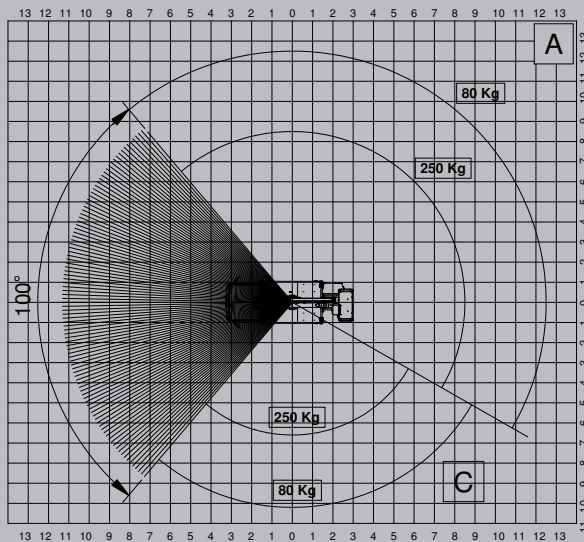
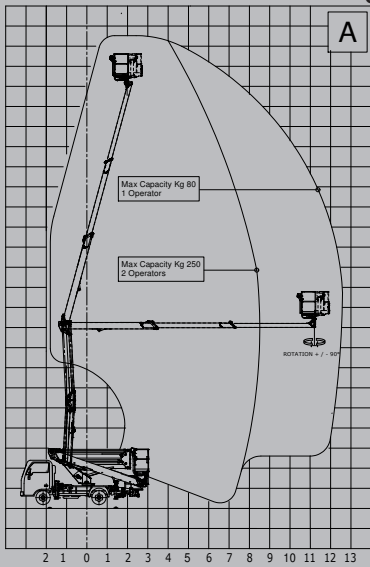

Snake 2413 plus

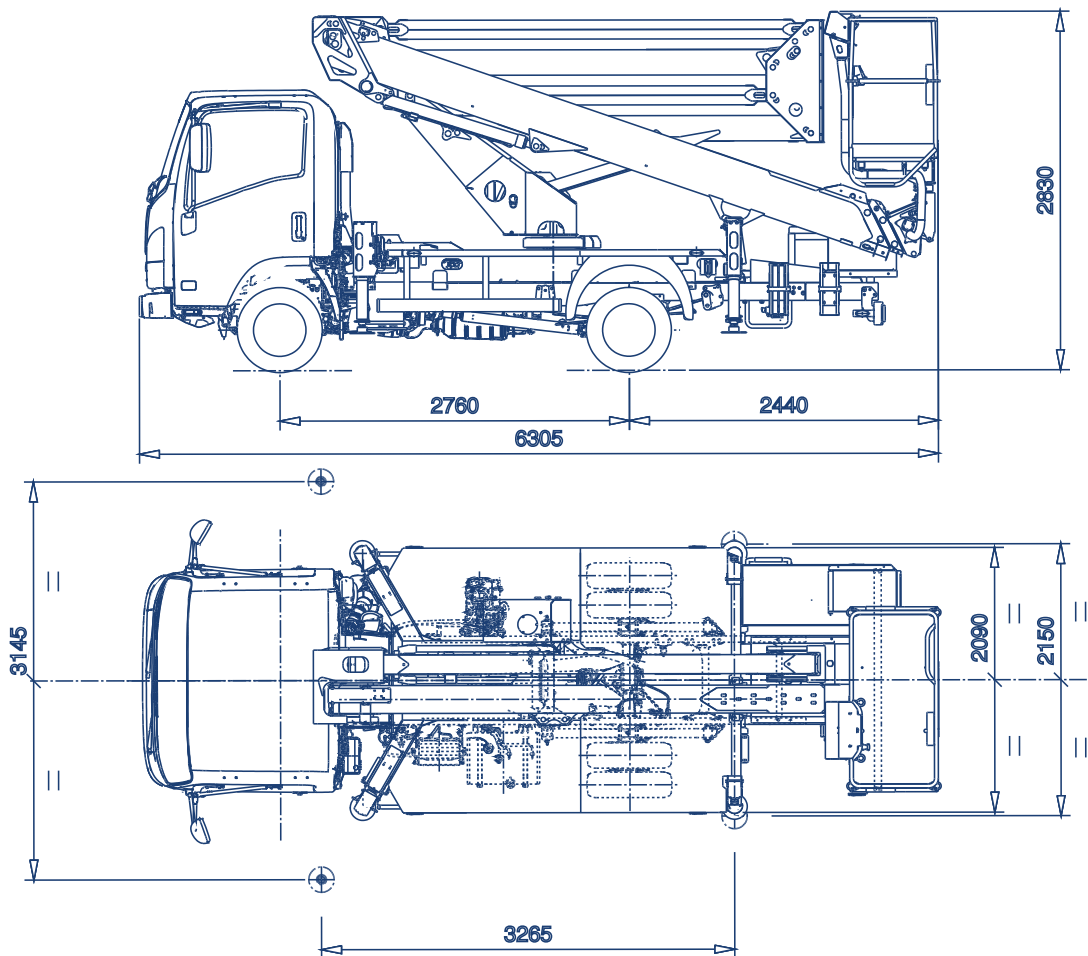

Technical data are purely indicative

TECHNICAL FEATURES

Max working height (m)	23,5 m
Max outreach (m)	12,6 m
Max basket capacity	250 kg
Basket dimensions	1400x700xh1100 mm aluminium [Fiberglass as optional]
Controls	Aerial part: electro-hydraulic Outriggers: hydraulic [electro-hydraulic as optional]
Turret rotation	400°
Basket rotation	90° left + 90° right
Outriggers	H Type
Machine length	6305 mm
Machine height	2830 mm
Machine width	2090 mm

All technical data, descriptions and illustrations are purely indicative and subject to change at PM Oil&Steel own discretion and without notice

PM Oil&Steel SpA

IT - 41018 S. Cesario Sul Panaro MO

Via G. Verdi, 22

tel. +39 059 936811 • fax +39 059 936804

info@oilsteel.it • www.oilsteel.com

Oil&Steel is a brand of Manitex International

OIL & STEEL
AERIAL PLATFORMS